

MANHOLE GENERAL NOTES:

- I.) ALL BRICK TO BE SOLID ENGINEERING BRICK CLASS A OR B
- II.) FOR PIPE DIAMETER >750MM USE MANHOLE WITH INTERNAL DIAMETER SIZE = PIPE SIZE + 1 METER + 300MM
- III.) DISTANCE FROM TOP RUNG OF THE LADDER TO GROUND LEVEL MUST BE A MAXIMUM OF 500MM

MANHOLE DRAWING NOTES:

- 225mm THICK CL20/20 MASS CONCRETE FOUNDATIONS.
- PREFORMED HALF CIRCLE CHANNEL PIPES. THE PIPELINE MAY WHERE PRACTICABLE, BE LAID THROUGH THE MANHOLE AND THE CROWN CUT OUT TO HALF DIAMETER, PROVIDED FLEXIBLE JOINTS ARE SITUATED ON EACH SIDE NO FURTHER THAN 600mm FROM THE INNER FACE OF THE MANHOLE WALL.
- MANHOLE CONSTRUCTION FOR SURFACE WATER MANHOLES HIGH DENSITY BLOCKS TO CL.S10 OF I.S.20 PART 1: 1987 OR CL.30/20 IN-SITU CONCRETE. BLOCKWORK SHALL BE BEDDED AND JOINTED USING MORTAR DESIGNATION THREE TO I.S.406. BEDS AND VERTICAL JOINTS SHALL BE COMPLETELY FILLED WITH MORTAR AS THE BLOCKS ARE LAID. JOINTS SHALL BE FLUSH POINTED AS THE WORK PROCEEDS. ALL FOUL MANHOLES MUST BE FACED IN SOLID ENGINEERING BRICK (MIN CLASS A OR B) OR IN-SITU CONCRETE FOR 1m ABOVE BENCHING LEVEL BRICK TO BE BONDED TO BLOCKWORK USING ENGLISH GARDEN WALL BOND.
- RELIEVING ARCH FORMED BY 215x103x65 BRICK CLASS A OR B AS PER DRAWING. RELIEVING ARCHES USED IN BRICK OR BLOCKWORK MANHOLES TO EXTEND OVER FULL THICKNESS OF WALL. A DOUBLE ARCH IS TO BE FORMED FOR PIPE DIAMETERS GREATER THAN 600mm.
- BENCHING AND PIPE CHANNEL PIPE SURROUND -CL.20/20 CONCRETE.
- BENCHING FINISHED IN 2:1 SAND-CEMENT MORTAR WITH SMOOTH TROWEL FINISH, AT 1 IN 30 SLOPE TOWARDS CHANNEL.
- STANDARD RUNGS AT 300c/c VERTICALLY AND GALVANISED TO LATEST VERSION OF BS729 OR EQUIVALENT.
- 600mm SQUARE OPE. IN ROOF SLAB.
- PRECAST R.C. ROOF SLAB SHALL BE 200MM THICK IN CL.30N/20MM CONCRETE, WITH 40MM COVER TO STEEL.
- 1 TO 2 COURSES OF SOLID ENGINEERING BRICKS CLASS B TO I.S.91:1983 SET IN HIGH STRENGTH MORTAR (MIN 60N AFTER 14 DAYS)
- CLASS D400 OR E600 MANHOLE COVER AND FRAME TO IS/EN 124. 150mm DEEP FRAME FOR ROADS, 100mm DEEP FOR FOOTPATHS AND GREEN AREAS. NON-ROCK DESIGN. CLOSED KEYWAYS, MANUFACTURED FROM SPHEROIDAL GRAPHITE CAST IRON (DUCTILE CAST IRON), 600x600 (OR 600 DIAM) CLEAR OPENING. COVER & FRAME COATED IN BITUMEN OR OTHER APPROVED MATERIAL. COVER TO HAVE A MINIMUM MASS OF 140kg/m². FRAME BEARING AREA SHALL BE 80,000mm² MIN. FRAMES SHALL BE DESIGNED TO PREVENT COVERS FALLING INTO MANHOLE. FRAMES SHALL BE BEDDED ON APPROVED MORTAR TO MANUFACTURER'S CONSTRUCTIONS.
- SHORT LENGTH PIPE, PIPE JOINT EXTERNAL TO MANHOLE SHALL NOT EXCEED 600mm FROM THE INNER FACE OF MANHOLE WALL.
- TOE HOLES OF 230mm MIN. DEPTH AND GALVANISED STEEL SAFETY RAILINGS TO BE PROVIDED IN BENCHING OF SEWERS GREATER THAN 525 DIAMETER, AND DEPTH TO INVERT >3m FOR ACCESS TO INVERT.
- SAFETY CHAIN TO BE PROVIDED ON PIPES THAT EXCEED 450mm IN DIAMETER. MILD STEEL SAFETY CHAIN SHALL BE 10mm NOMINAL SIZE GRADE (M)H NON CALIBRATED CHAIN TYPE 1, COMPLYING WITH BS: 4942 Part 2 OR EQUIVALENT.
- WHEN DEPTH OF MANHOLES TO INVERT IS GREATER THAN 3.0m LADDERS SHALL BE USED, INSTEAD OF RUNGS, TO BS4211 EXCEPT THAT STRINGERS SHOULD BE NOT LESS THAN 65x12mm IN SECTION AND RUNGS 25mm IN DIAMETER. FIXED LADDERS SHOULD MEET THE DIMENSIONAL REQUIREMENTS OF BS 4211.
- LADDER STRINGERS SHOULD BE ADEQUATELY SUPPORTED FROM THE MANHOLE WALL AT INTERVALS OF NOT MORE THAN 2.0m. STRINGERS SHOULD BE BOLTED TO CLEATS TO FACILITATE RENEWAL.
- ALL LADDERS, RUNGS, HANDRAILS, SAFETY CHAINS ETC. SHALL BE HOT DIP GALVANISED TO BS729.
- SOCKET OF PIPE SHOULD BE CUT FLUSH WITH THE INSIDE SURFACE OF THE MANHOLE WALL SO THAT THE CHANNEL EXTENDS FULL LENGTH OF THE MANHOLE (EXCEPT FOR PRECAST MANHOLES).
- POSITION OF 910 SQUARE OPENING IN INTERMEDIATE ROOF SLAB.
 - ALL MANHOLES SHALL BE WATERTIGHT TO THE SATISFACTION OF THE ENGINEER.
 - FORMWORK TO REINFORCEMENT CONCRETE AND MASS CONCRETE SHALL COMPLY TO CLASS 2, SECTION 6.2.7, BS8110: PART 1: 1997.
 - FINISH TO THE TOP OF SLABS SHALL COMPLY TO TYPE A, SECTION 6.2.7, BS8110: PART 1: 1997.
 - PLAN DIMENSIONS OF MANHOLES ARE BASED ON BLOCKWORK HAVING A CO-ORDINATING SIZE OF 450x225x100.
 - MANHOLES ARE DESIGNED TO BS8005 AND WALL THICKNESSES TO IS325 BLOCKWORK DESIGN CODE TAKING GRANULAR FILL PRESSURE AND H.B. SURCHARGE.
 - REINFORCEMENT TO SLABS TO ENGINEERS DETAILS.
- FOR MANHOLES >3.0m DEPTH TO INVERT USE 30N/20 IN-SITU CONCRETE. REINFORCING MESH REF. A393 @6.16kg/m TO BE FIXED AT MID POINT OF WALL. ADDITIONAL REINFORCEMENT TO BE SUPPLIED OVER PIPE CROWN.
- FOR PRECAST MANHOLES, CHAMBER WALLS AND COVER SLAB TO BE CONSTRUCTED TO IS EN 1917 AND IS 420 2004.
- MANHOLE OPENING TO BE SITUATED FURTHEST FROM THE NEAREST CARRIAGEWAY. MANHOLE STEPS/ACCESS TO BE POSITIONED TO ALLOW VIEWING OF ONCOMING TRAFFIC.
- FOR BEDDING AND SEALING OF CHAMBER RINGS. THE TOP RING (TO PRECAST COVER SLAB) AND BOTTOM RING TO BE BEDDED WITH CEMENT MORTAR. FOR INTERMEDIATE RINGS. JOINTS TO BE SEALED WITH APPROVED PRE-FORMED JOINTING STRIP.
- PRECAST MANHOLES TO BE SURROUNDED WITH A MINIMUM OF 150MM THICK GRADE C20/40 CONCRETE

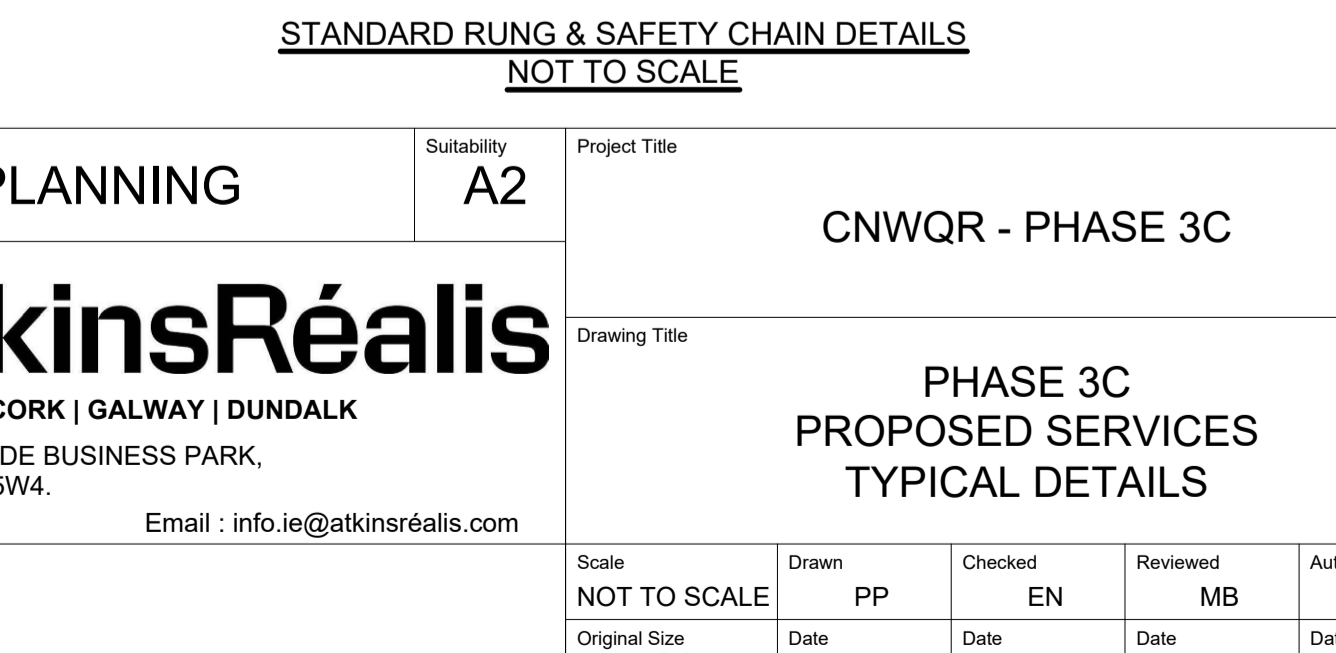
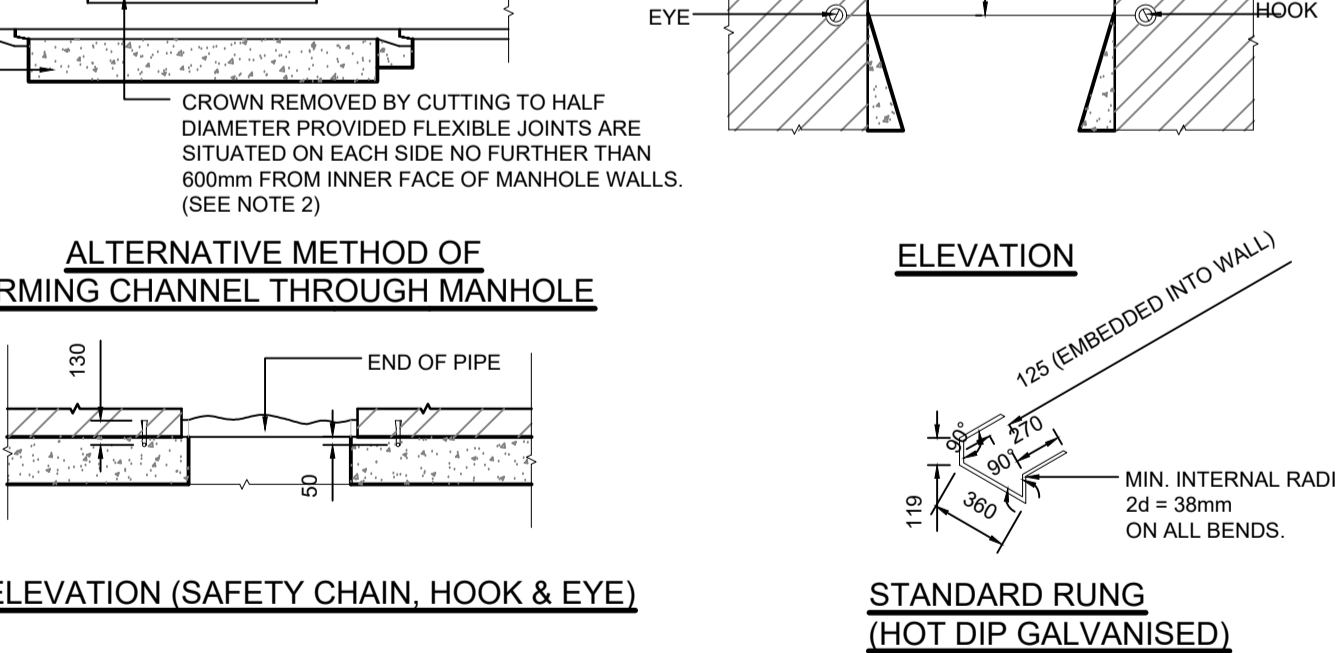
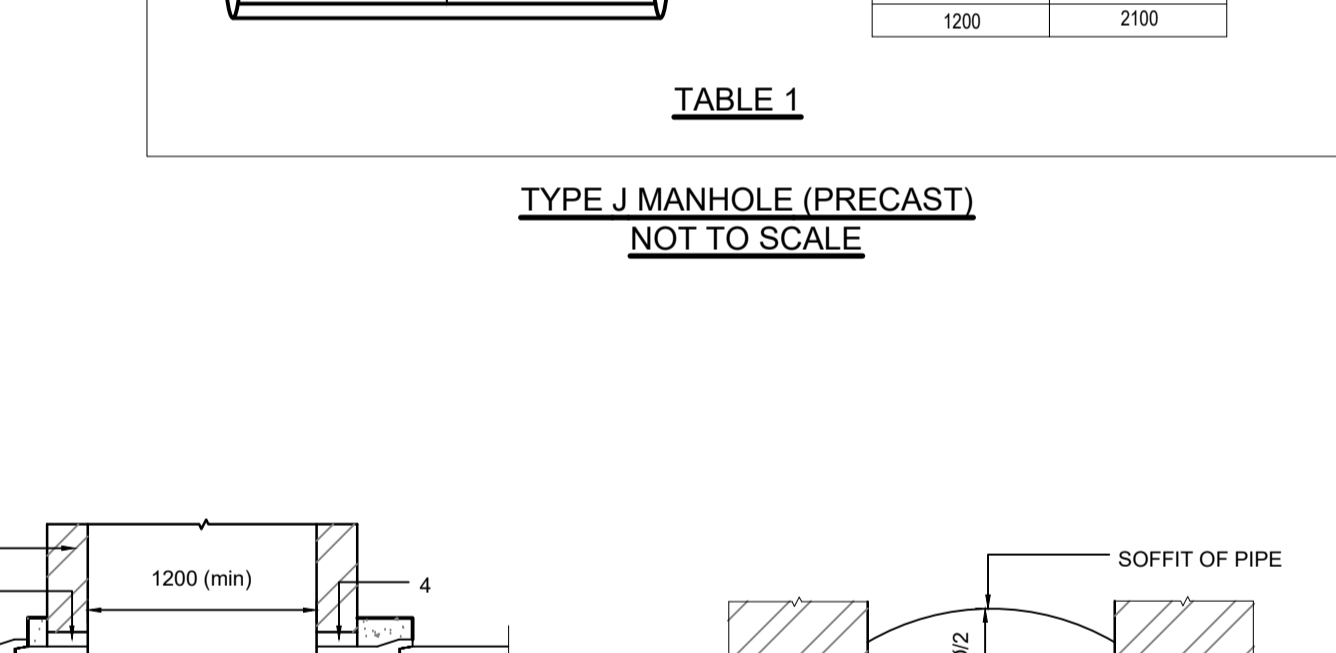
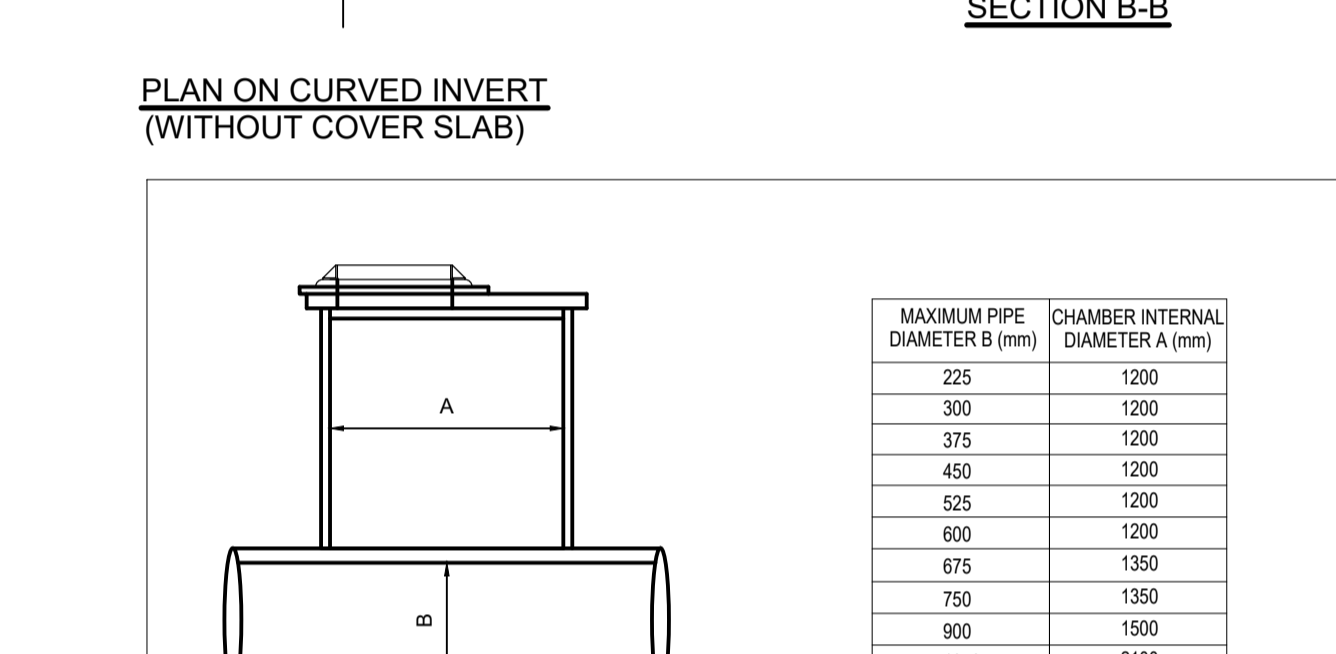
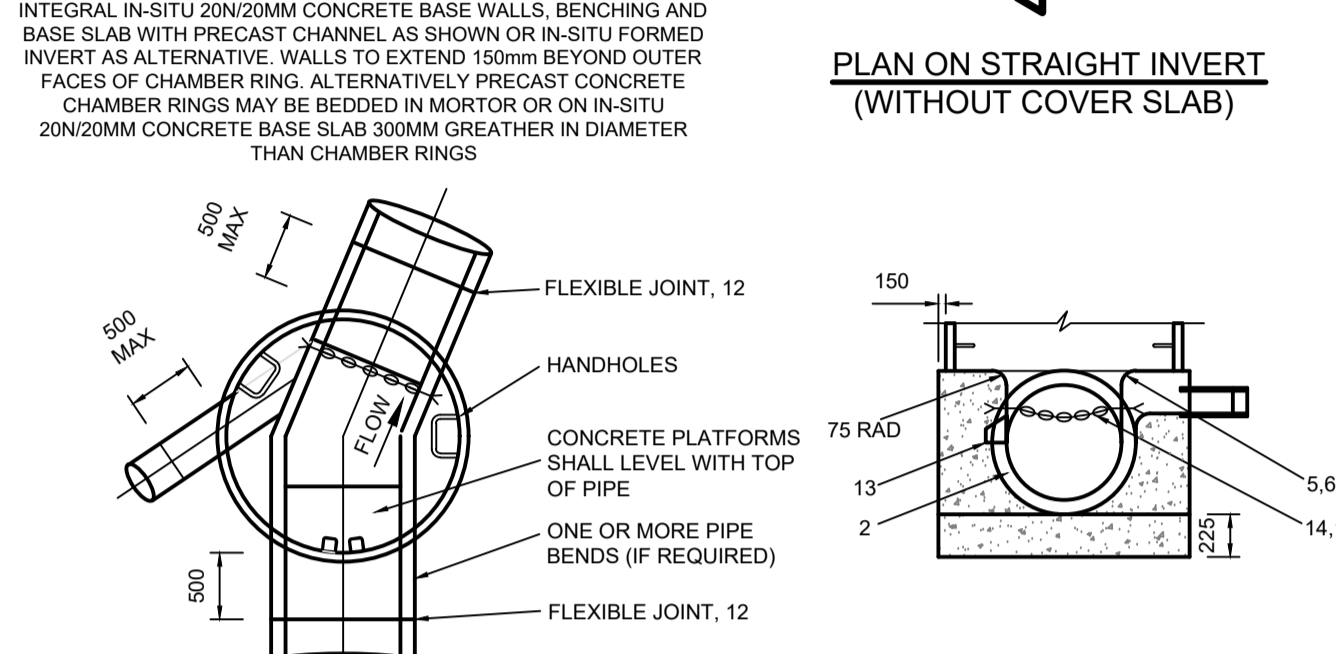
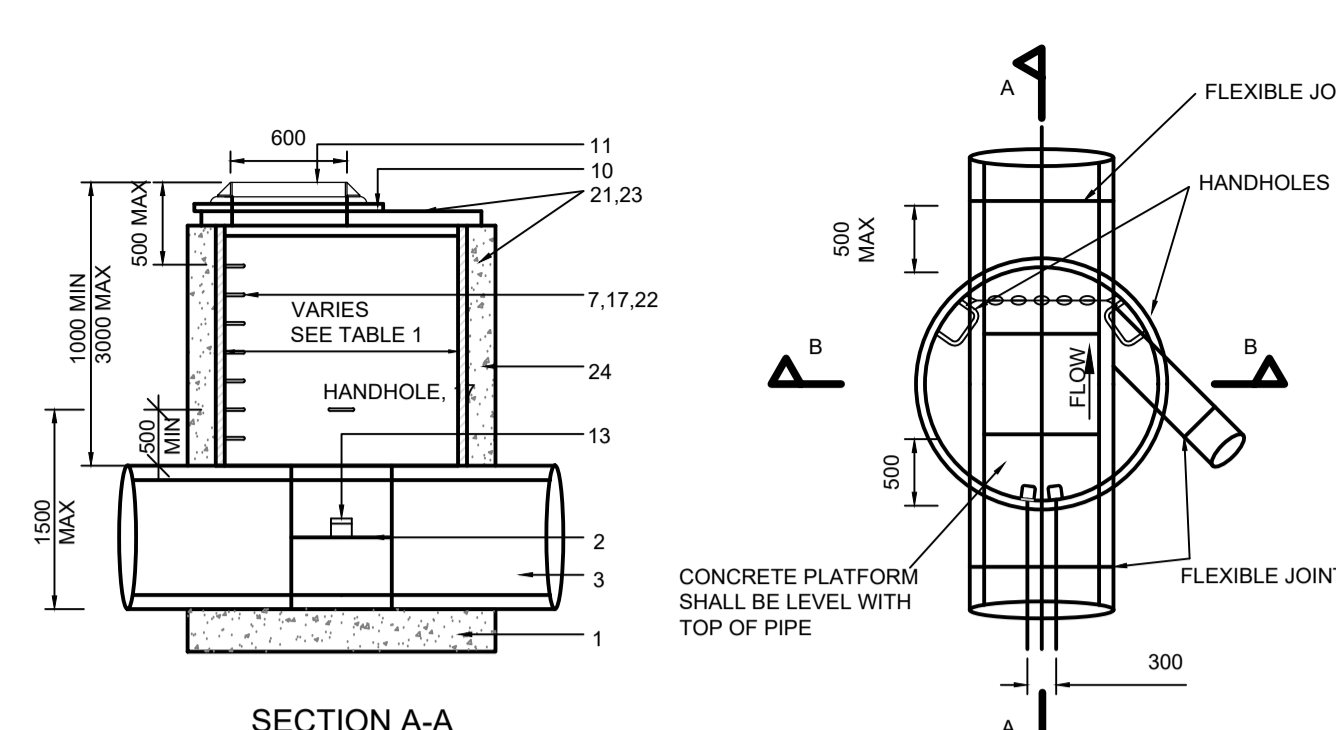
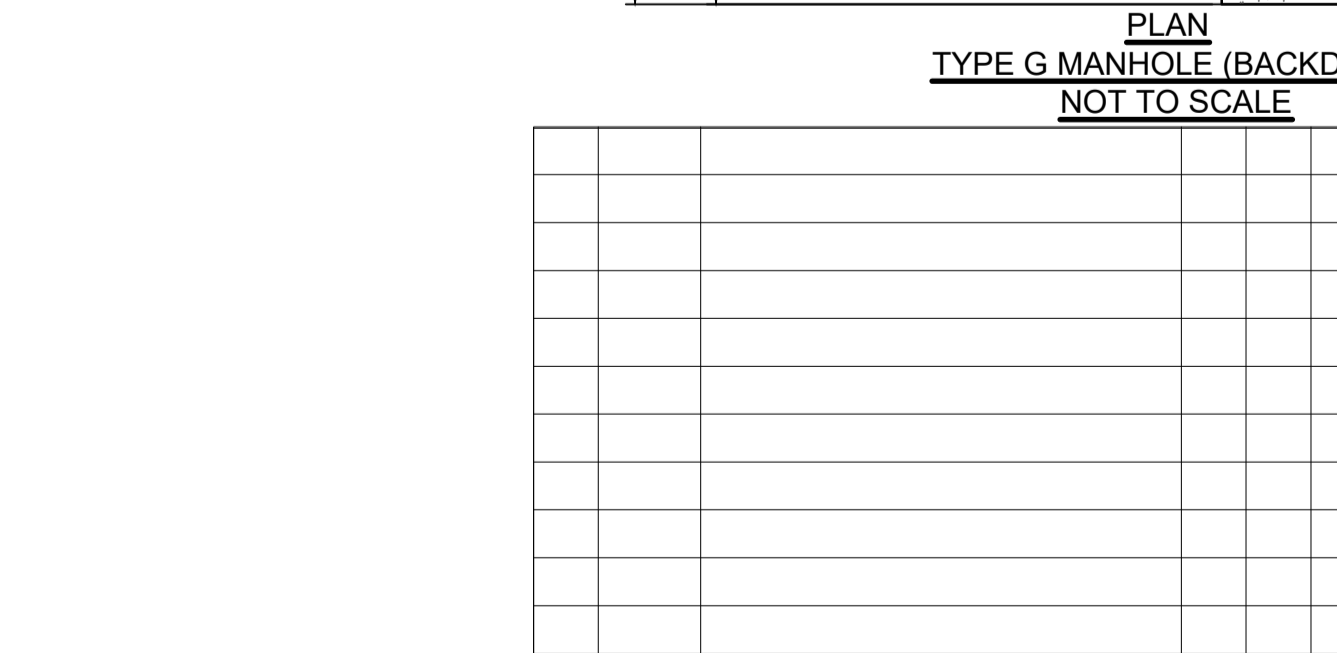
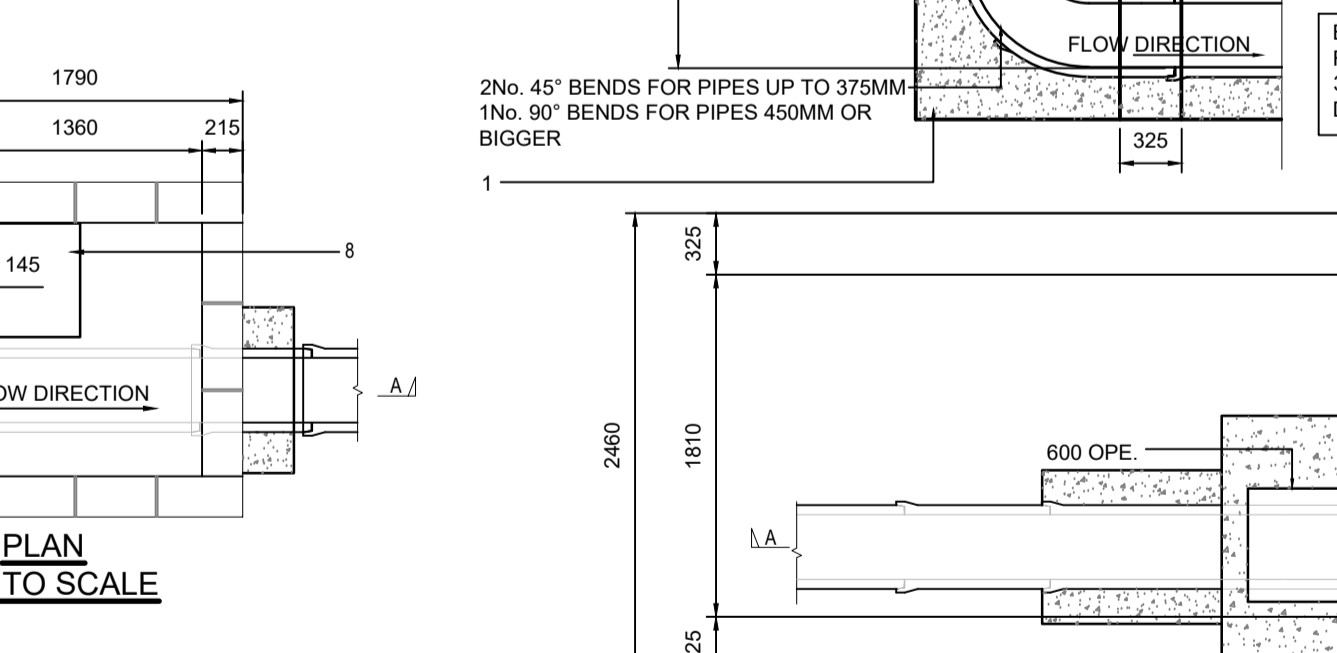
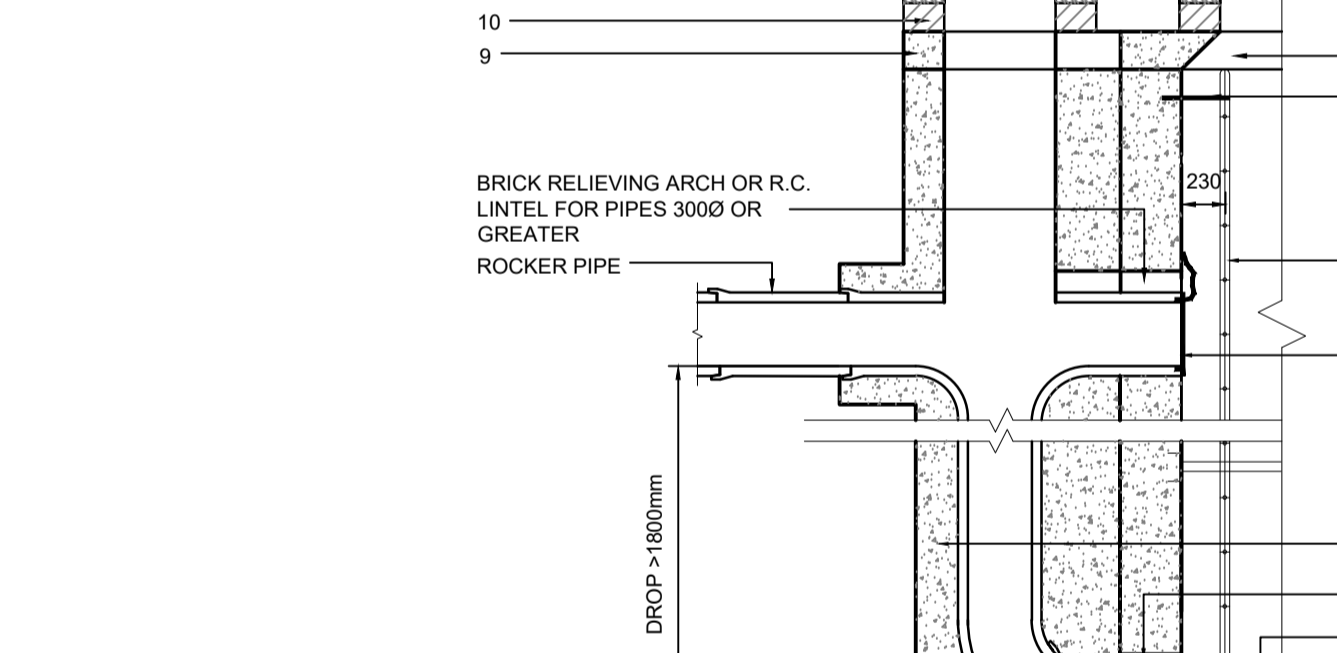
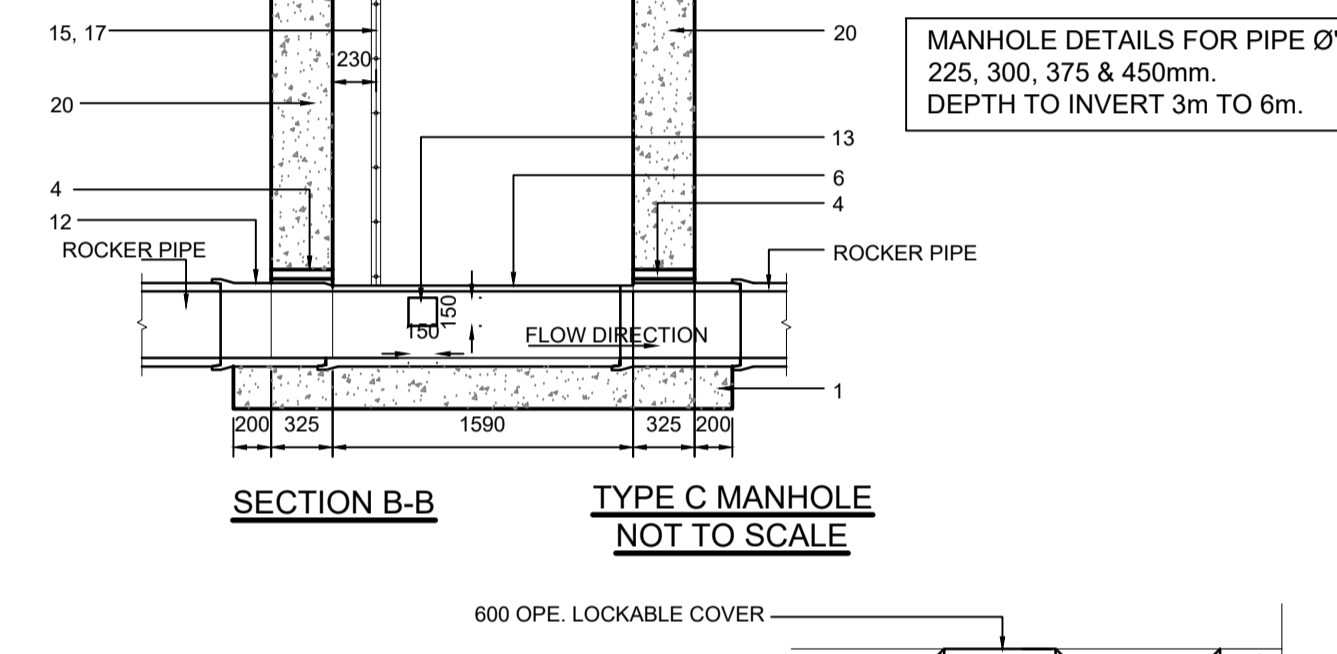
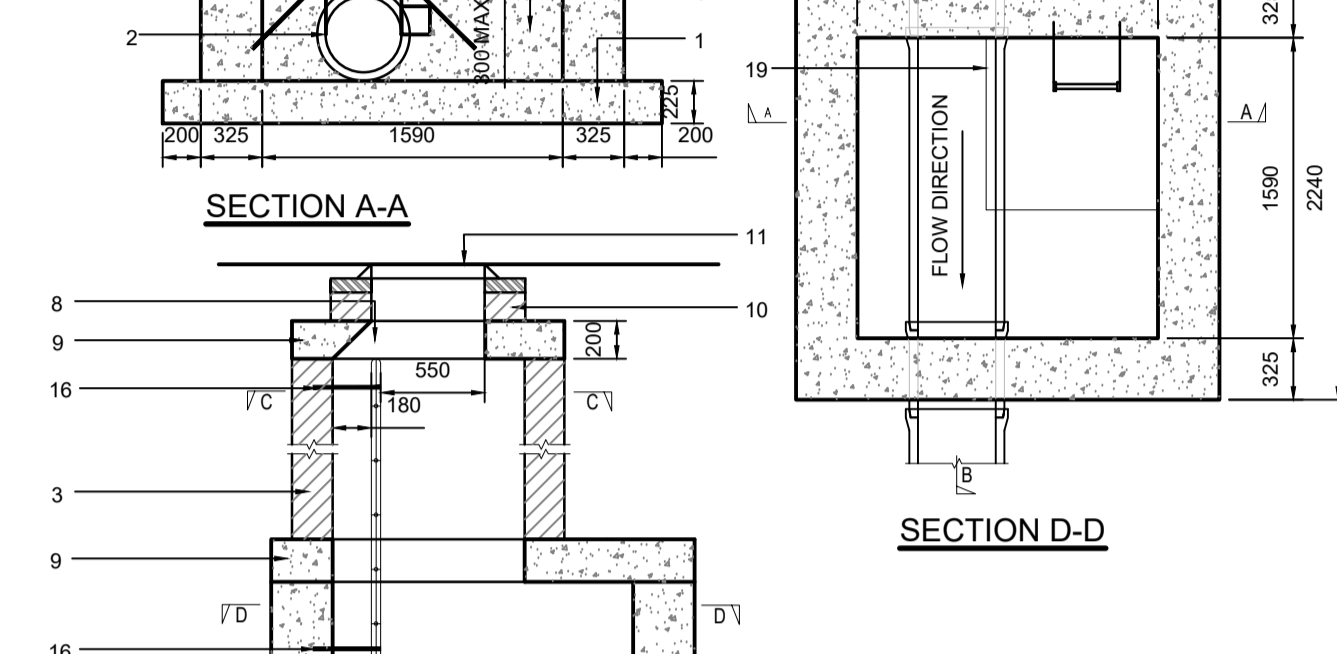
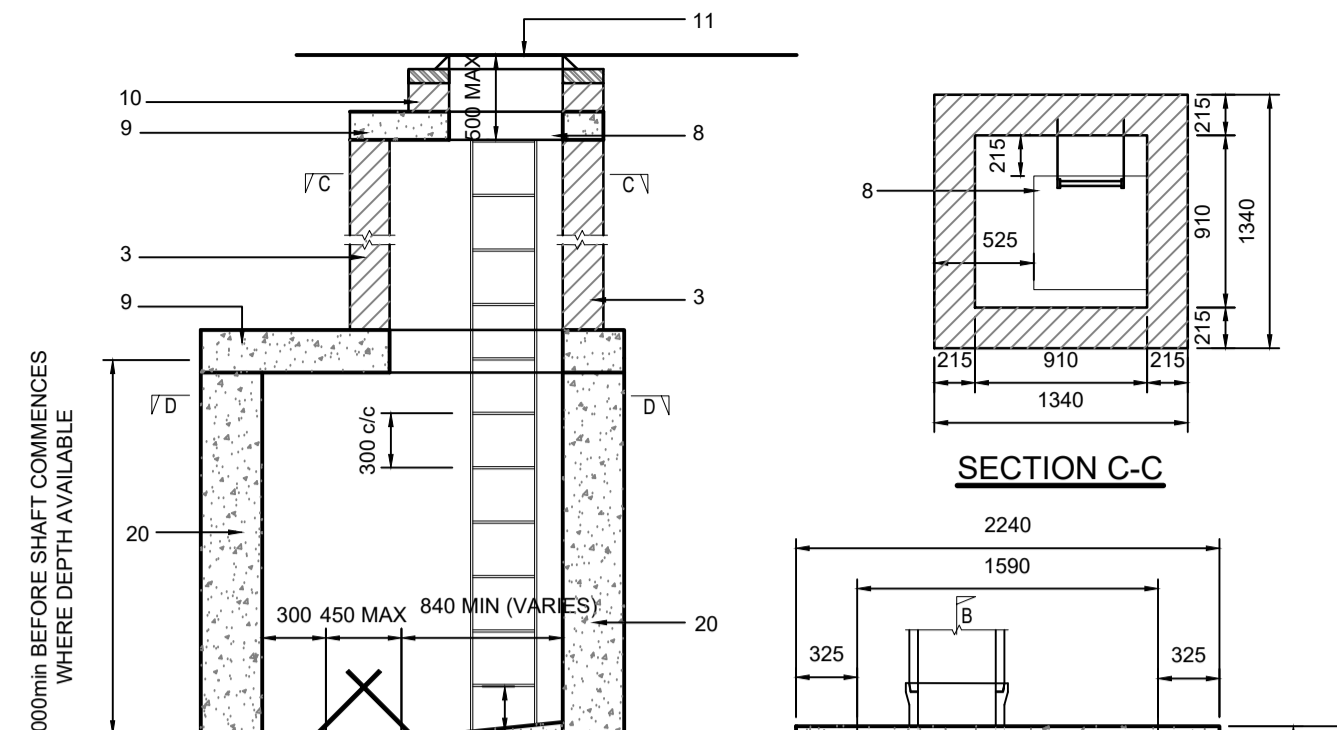
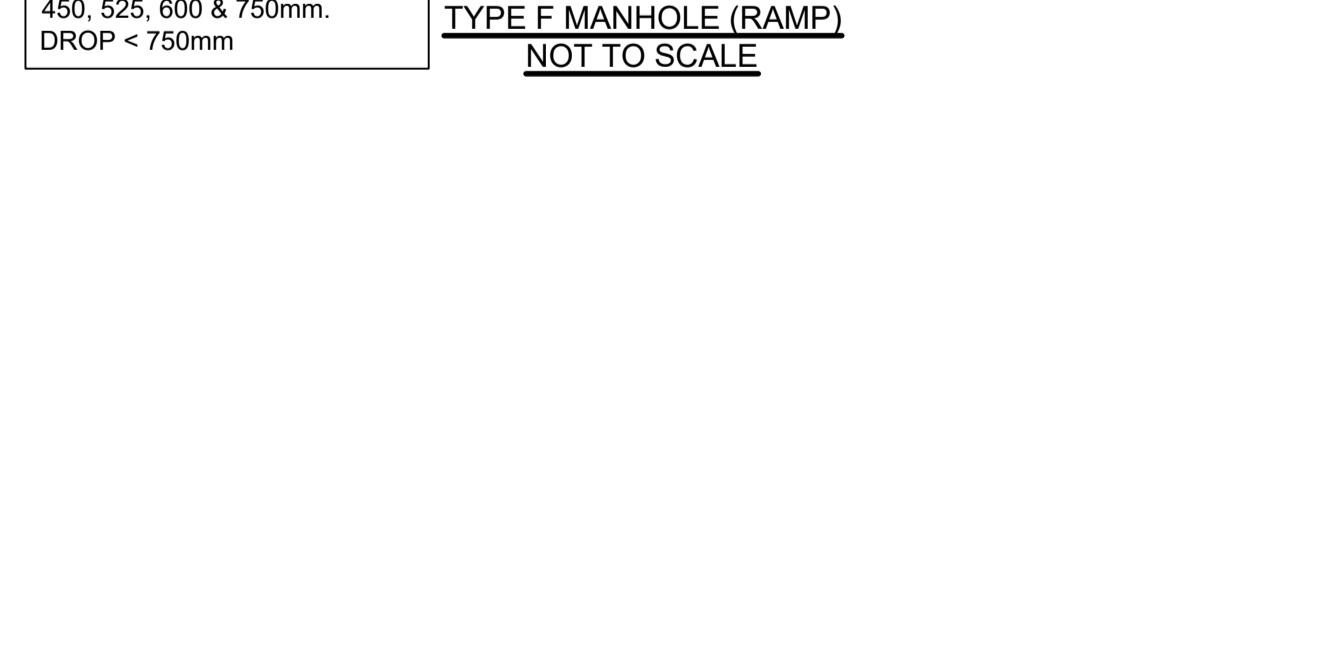
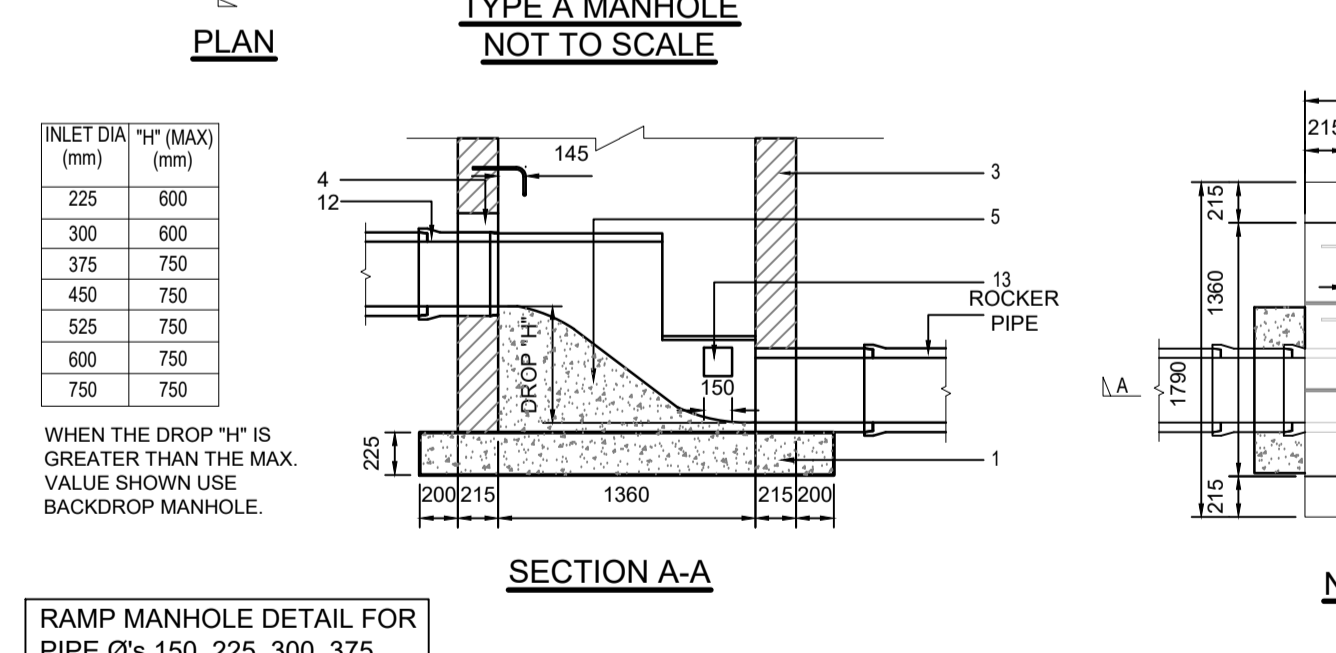
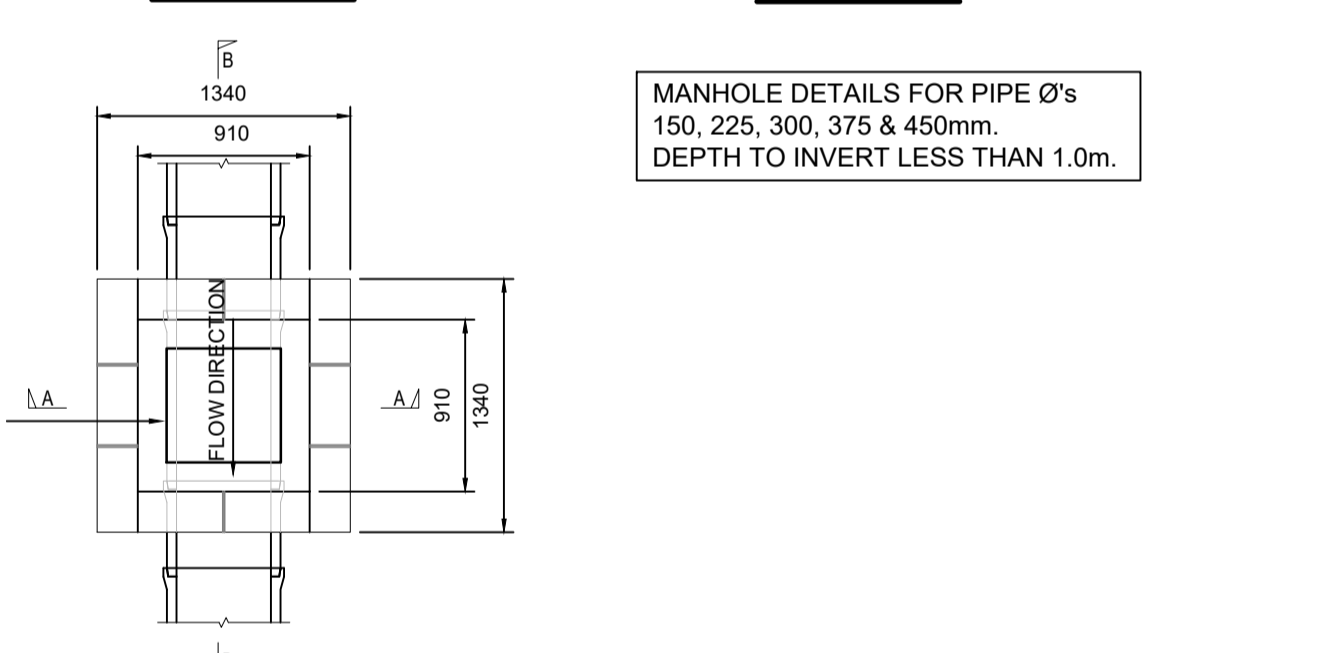
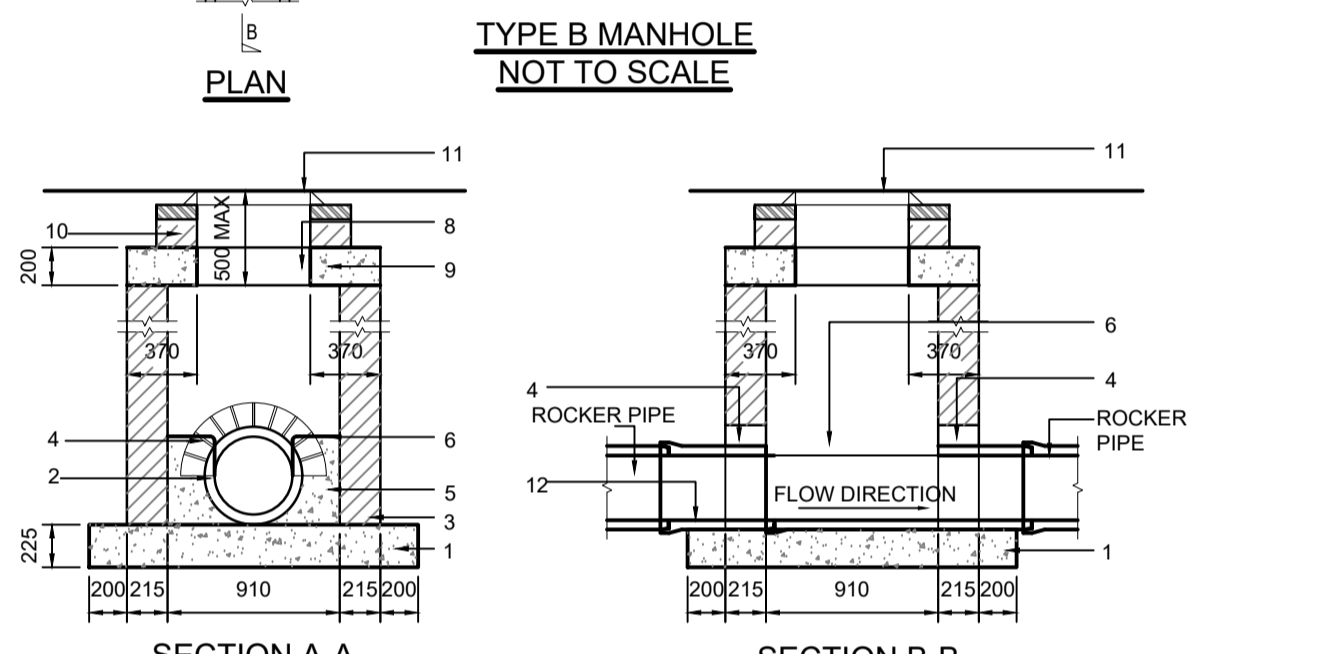
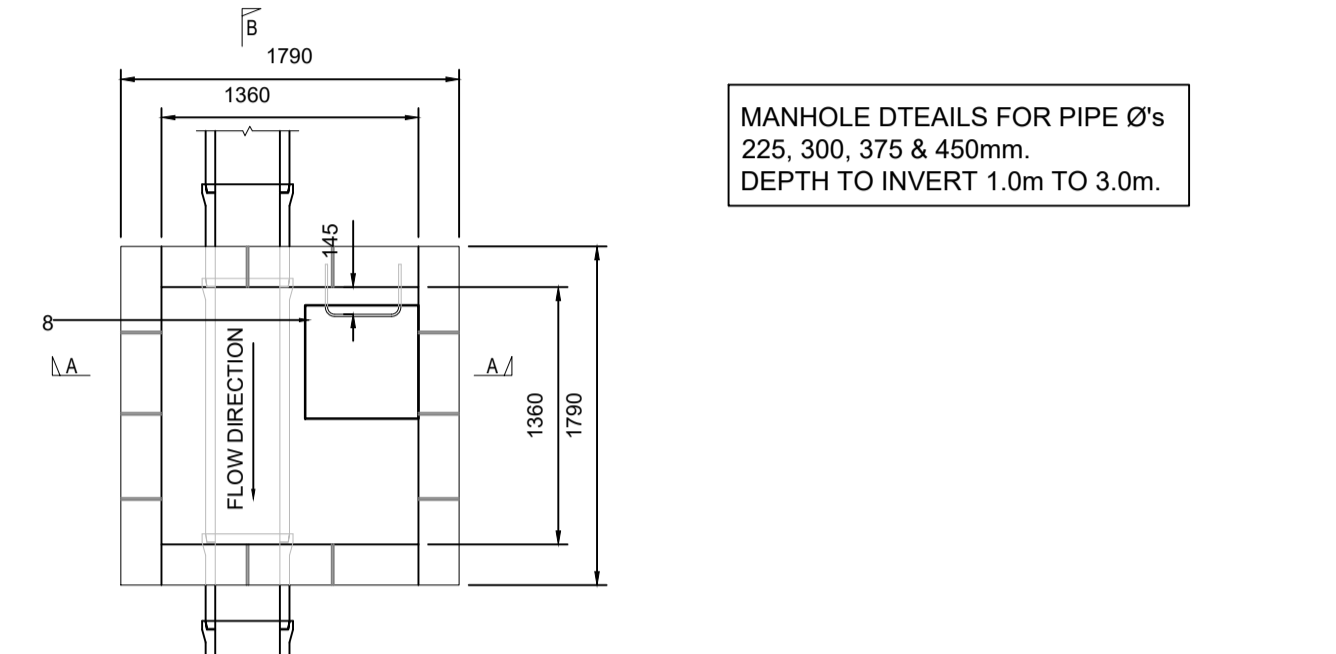
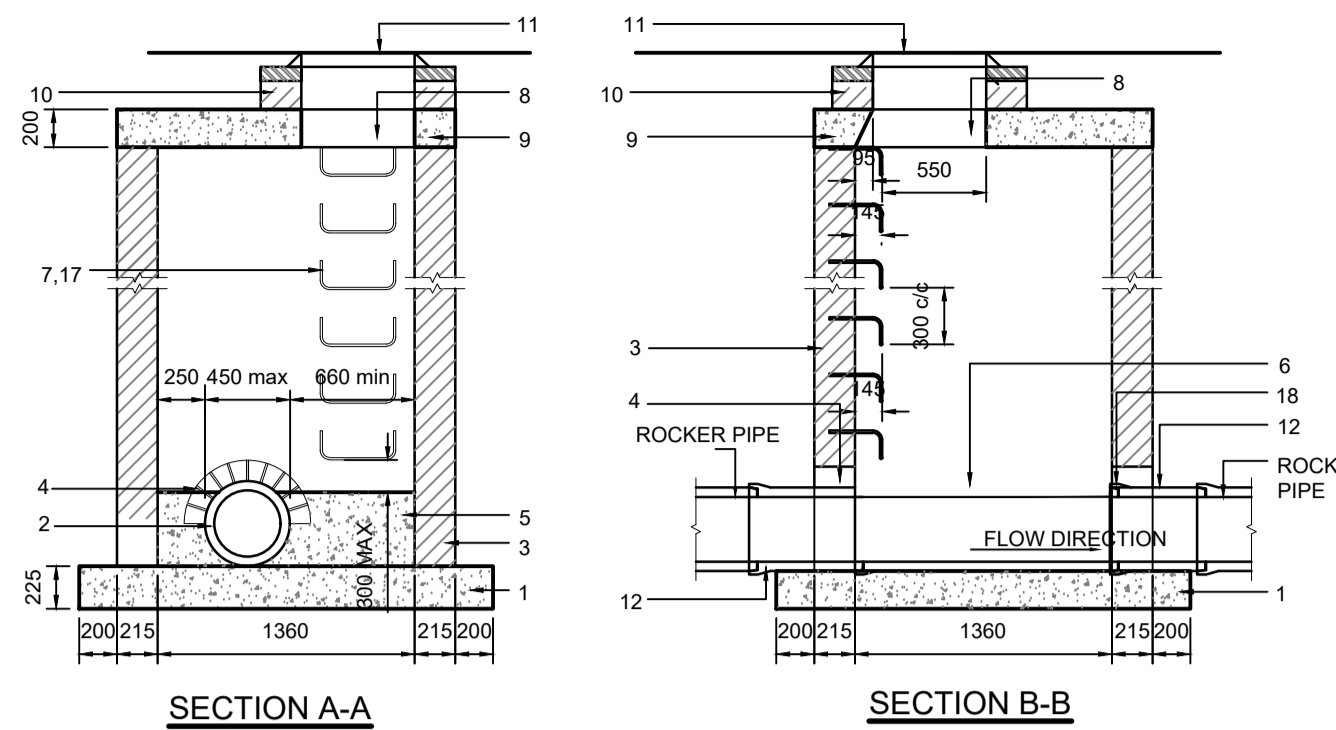

TABLE 1

MAXIMUM PIPE DIAMETER B (mm)	CHAMBER INTERNAL DIAMETER A (mm)
225	1200
300	1200
375	1200
450	1200
525	1200
600	1200
675	1350
750	1350
900	1500
1050	2100
1200	2100

FOR PLANNING

AtkinsRéalis

DUBLIN | CORK | GALWAY | DUNDALK

ATKINS HOUSE, 150 AIRSIDE BUSINESS PARK, SWORDS, DUBLIN, K67 K5W4. Tel: +353 1 810 8000 Email: info.ie@atkinsrealis.com

Client: CORK CITY COUNCIL

Project Title: CNWQR - PHASE 3C

Drawing Title: PHASE 3C PROPOSED SERVICES TYPICAL DETAILS

Scale	Drawn	Checked	Reviewed	Authorised
NOT TO SCALE	PP	EN	MB	MOS
Original Size	Date	Date	Date	Date
A3	27.03.26	27.03.26	27.03.26	27.03.26
Drawing Number	Revision			
P3C-XXX-XXX-DR-ATK-CE-960590	C00			

100

Millimetres

0 10

P:\VECKA\datastore\0119710\6 Dwg-Graphics\62_P3C\61 AutoCad\P3C-XXX-XXX-DR-ATK-CE-960590.dwg

Atkins Project Number: 100119710