

DO NOT SCALE. WORK TO FIGURED DIMENSIONS ONLY.  
 ALL EXISTING DIMENSIONS TO BE CHECKED ON SITE.  
 DRAWN ON AUTOCAD R2004 AT DEADY GAHAN ARCHITECTS LTD  
 LAYERS ON THIS DRAWING COMPLY WITH BS 1192: PART 5

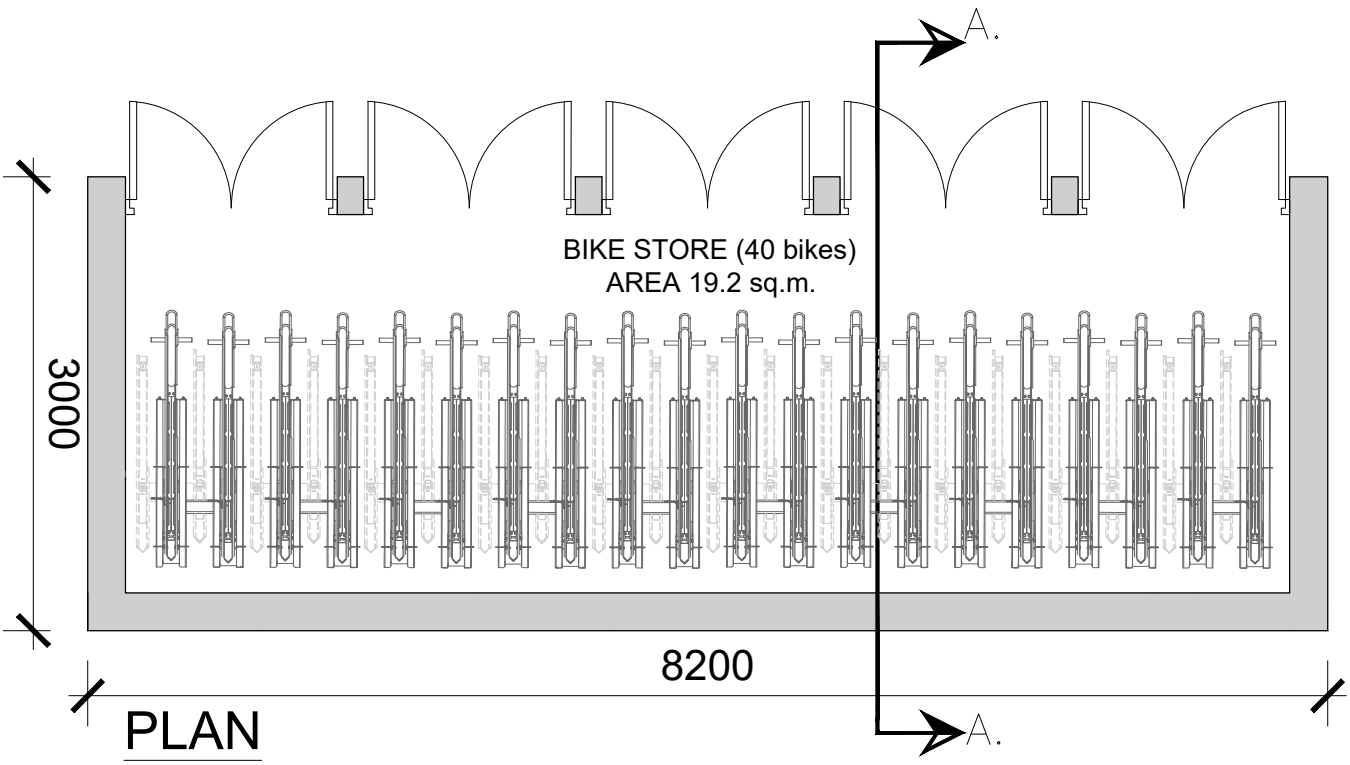

**PLAN**  
 Scale 1:50

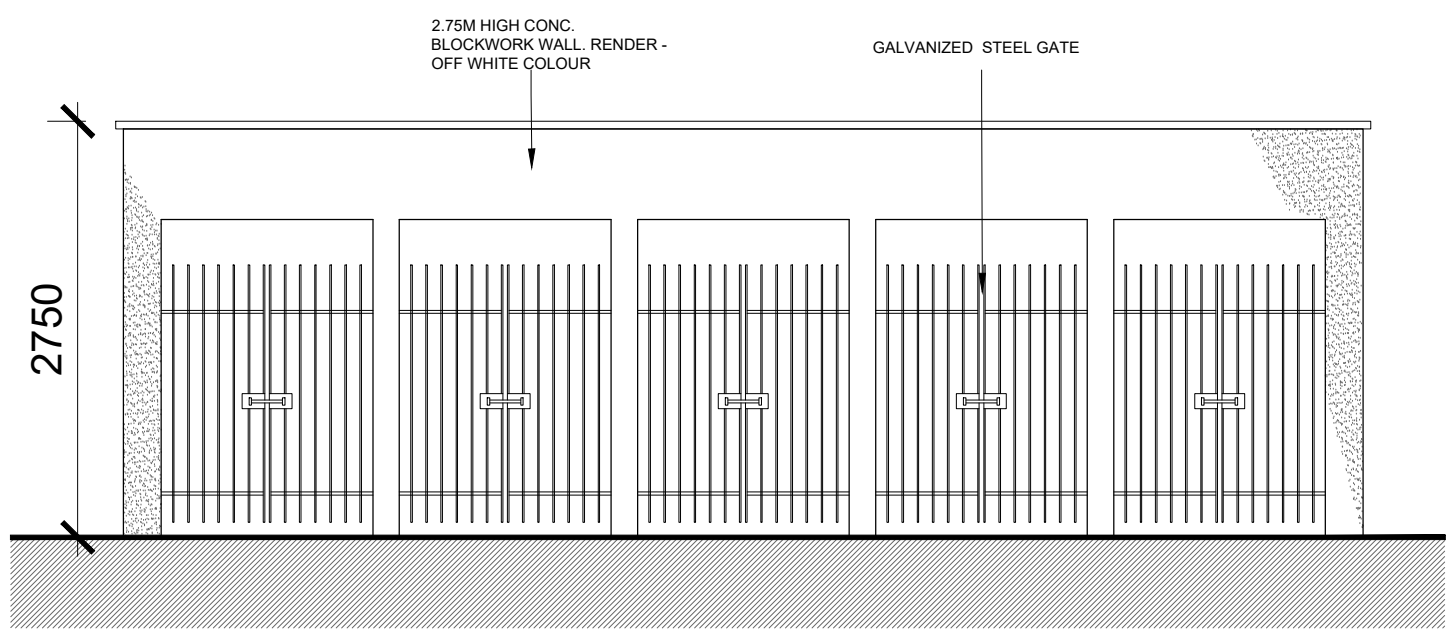

**FRONT ELEVATION**  
 SCALE 1:50

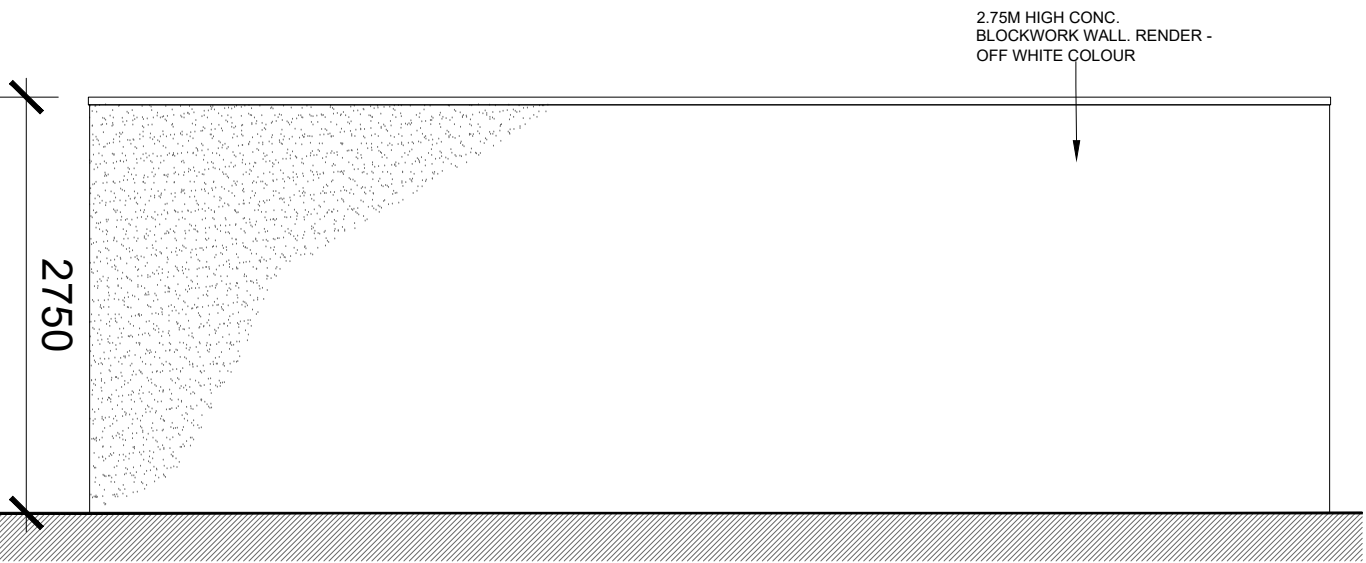

**REAR ELEVATION**  
 Scale 1:50

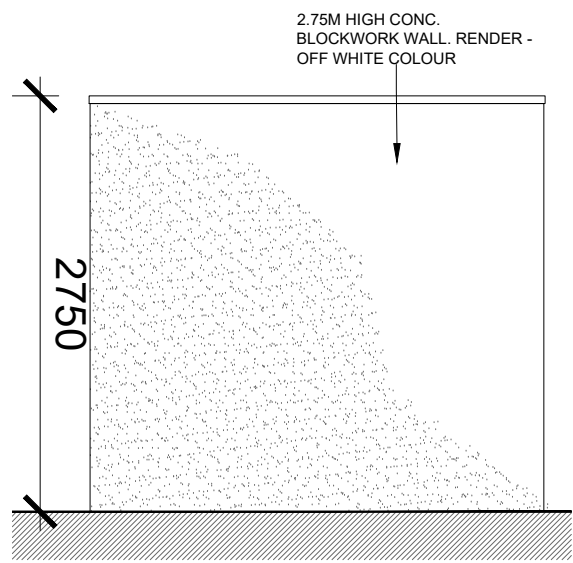

**SIDE ELEVATIONS**  
 Scale 1:50

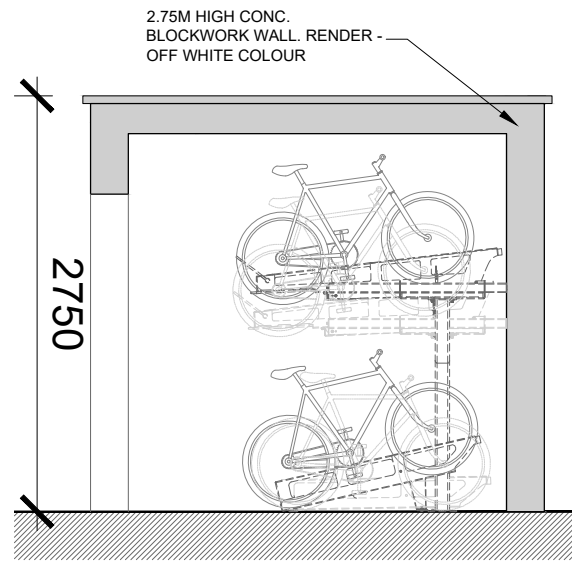

**SECTION A-A**  
 Scale 1:50

**SCHEDULE OF PARKING**

**TOTAL BIKE PARKING SPACES**  
 74 No. Spaces provided\*

\*Follows standards set out in the Design Standards for New Apartments document (2020):

**Residents**  
 24 x (1-bed apts.) = 1.5 space per apt.  
 15 x (2-bed apts.) = 2.5 space per apt.  
 74 spaces Provided

TOTAL: 74 bike spaces required

\*A total No. of 40 sheltered bicycle spaces have been provided in the courtyard with 34 No. bicycle spaces has been provided within the building footprint.

date	rev	name	chk	note
03.06.22	P1	MP	EJG	ISSUE FOR PLANNING

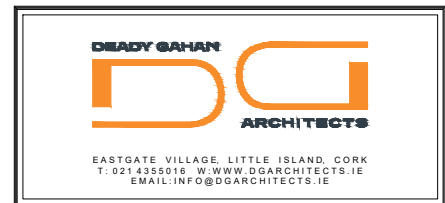

Project  
 PROPOSED RESIDENTIAL DEVELOPMENT  
 ON KINSALE ROAD, CO. CORK.

Drawing title  
 PROPOSED BIKE STORE

Scale 1:50 @ A3	Drawn MP	Checked EJG	Date 17.12.21
Project No. 21002	Orig. No. 21002/P006	Revision P1	

Information \ Comments  Tender   
 Planning  Construction

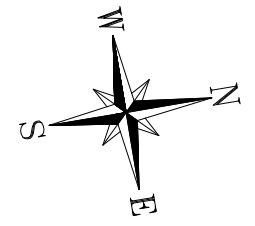

F.F.L. +100.2

**PROPOSED BIKE STORE**  
 SCALE 1:50 @ A3