

DO NOT SCALE. WORK TO FIGURED DIMENSIONS ONLY.
 ALL EXISTING DIMENSIONS TO BE CHECKED ON SITE.
 DRAWN ON AUTOCAD R2004 AT DEADY GAHAN ARCHITECTS LTD
 LAYERS ON THIS DRAWING COMPLY WITH BS 1192: PART 5

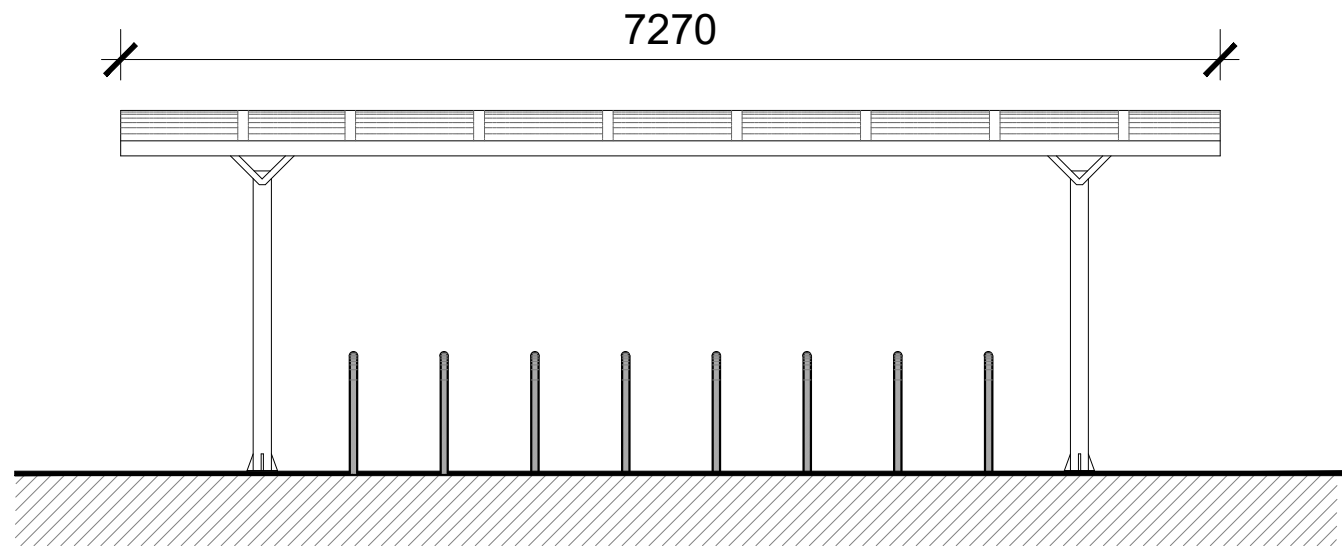

FRONT ELEVATION

SCALE 1:50 @ A3

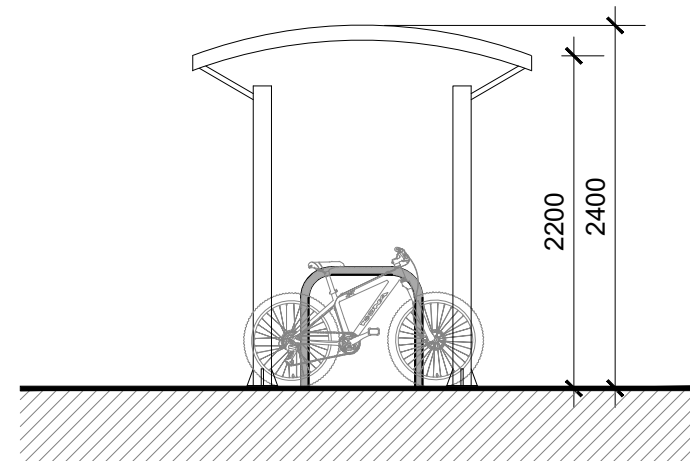

SECTION A-A

SCALE 1:50 @ A3

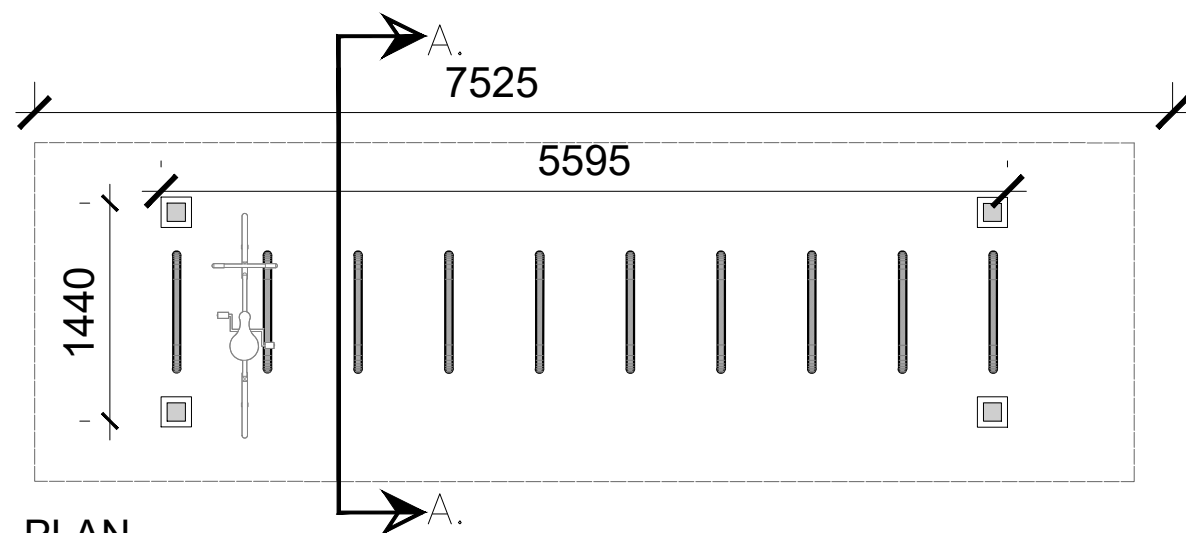

PLAN

SCALE 1:50 @ A3



KEY PLAN

NTS @ A3

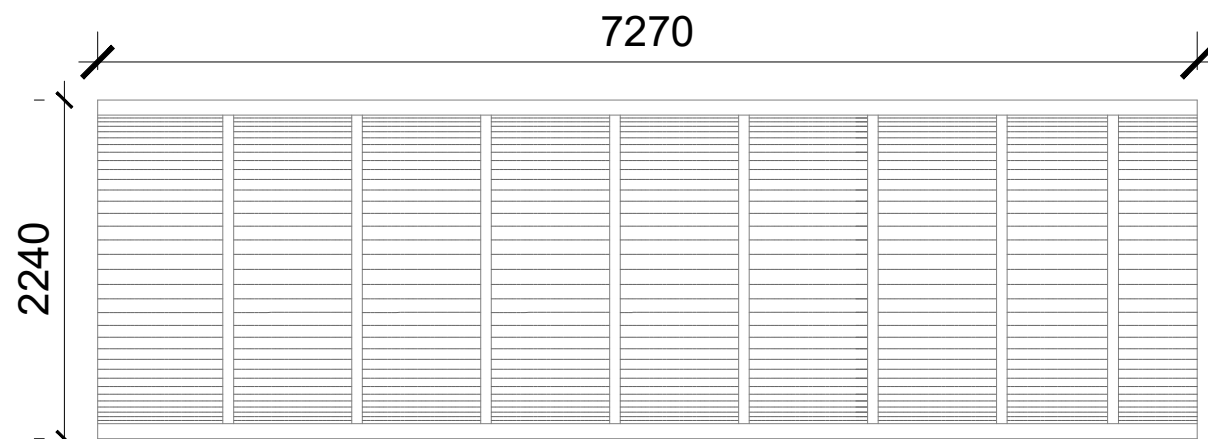

ROOF PLAN

SCALE 1:50 @ A3

PROPOSED TYPICAL BIKE STORE

1:50 @A3



BIKE RACK IMAGE

NTS @ A3

BIKE PARKING SCHEDULE

APARTMENTS
 (28 no. 1 beds, 30no. 2 beds & 23no. 3 beds
 within all Blocks)

- 197no. bike spaces required including visitor spaces

- 1 Bike rack 1
20no. spaces (Covered)
- 2 Bike rack 2
32no. spaces (Covered)
- 3 Bike rack 3
32no. spaces (Covered)
- 4 Bike rack 4
20no. spaces (Covered)
- 5 Bike rack 5
20no. spaces (Covered)
- 6 Bike store 6
80no. spaces (Covered)
(Located in Coach House)

Total = 204no. spaces*

*Exceeds standards set out in the Design Standards for New Apartments document (2023):

date	rev	name	chk	note
04.03.25	P1	MP	EJG	ISSUE FOR PLANNING



Project
 PROPOSED RESIDENTIAL DEVELOPMENT
 AT GLYNTOWN, GLANMIRE, CORK

Drawing title
 PROPOSED TYPICAL BIKE STORE

Scale	Drawn	Checked	Date
1:50 @A3	PD	EJG	04.03.25
Project No.	Dr. No.	Revision	
21061	21061/P/007	P1	

<input type="checkbox"/> Information \ Comments	<input type="checkbox"/> Tender
<input checked="" type="checkbox"/> Planning	<input type="checkbox"/> Construction